

Schnitt A-A

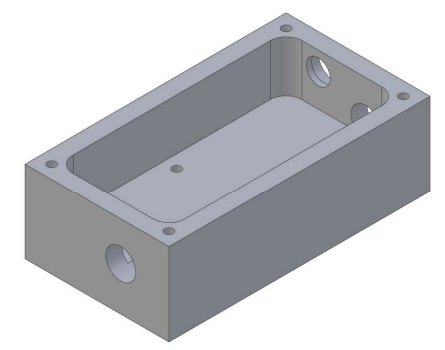

Maßstab 1:1

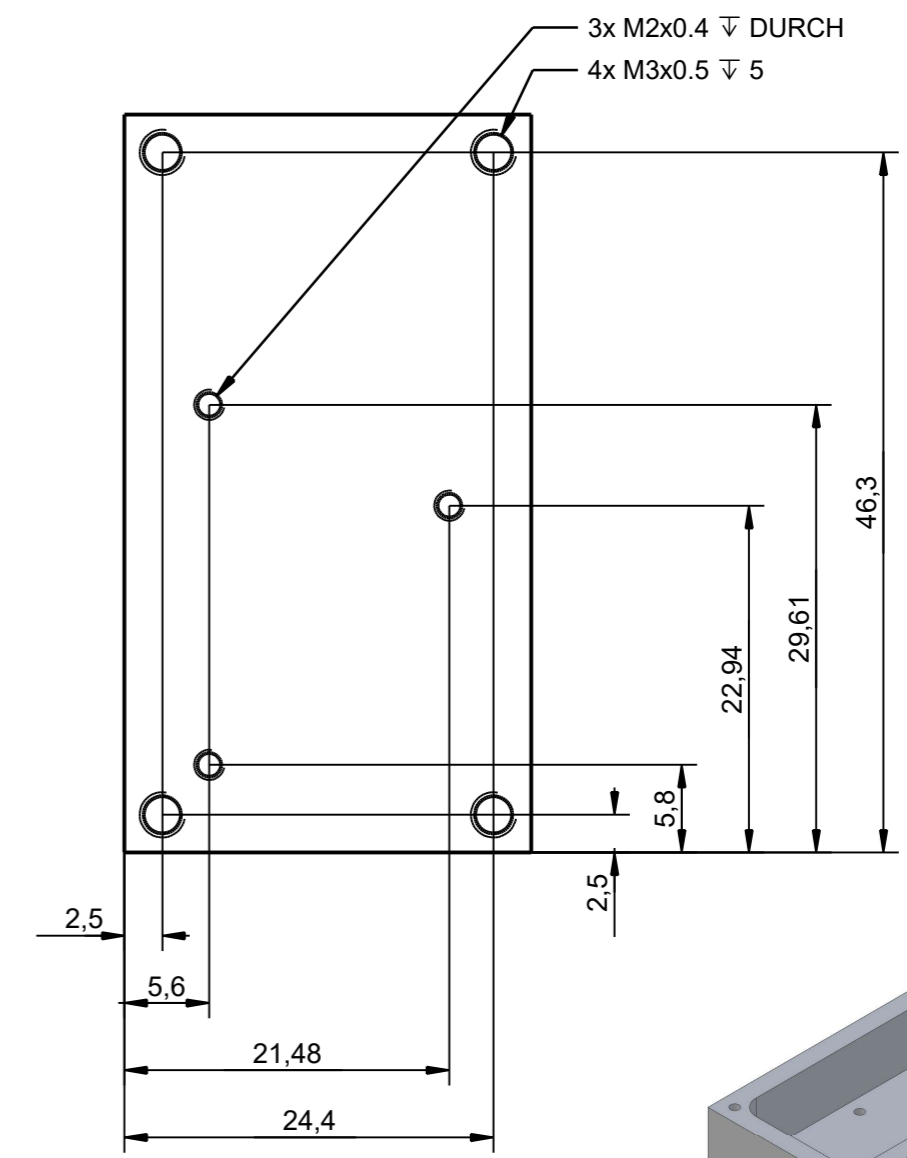
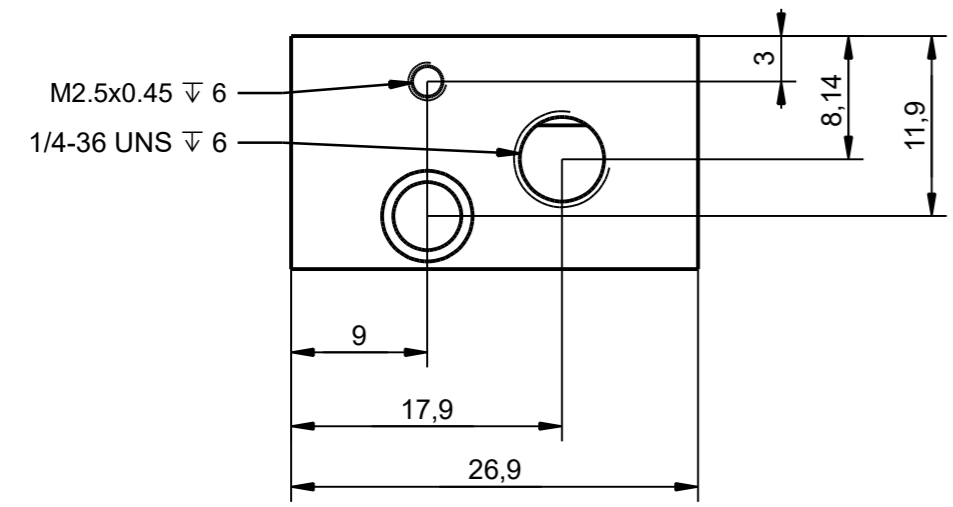

20.07.2020 tsu: Zeichnung korrigier bzw. vervollständigt

Alle Kanten gratfrei, alle Oberflächen öl- und fettfrei	Maßstab M 2:1	Art.-Nr.: 53512-110
Toleranzen nach DIN ISO 2768-mK	Werkstück-Kanten: DIN 6784	Datum: 20.09.2018
<a href="http://www.barthel-hf.com">barthel HF-Technik GmbH</a> <a href="http://www.barthel-hf.com">www.barthel-hf.com</a>	Zeichner: M. Bier	Material: Alu
	Gehäuse LNA Wanne	Oberfläche: